

Typical Applications

- 2.5GHz ISM Band Applications
- Digital Communication Systems
- PCS Communication Systems
- Commercial and Consumer Systems
- Portable Battery-Powered Equipment

Product Description

The RF2126 is a high-power, high-efficiency, linear amplifier IC. The device is manufactured on an advanced Gallium Arsenide Heterojunction Bipolar Transistor (HBT) process and has been designed for use as the final RF amplifier in 2.45 GHz ISM applications such as WLAN and POS terminals. The part will also function as the final stage in digital PCS phone transmitters requiring linear amplification operating between 1800MHz and 2500MHz. The device is packaged in an 8-lead plastic package with a backside ground. The device is self-contained with the exception of the output matching network and power supply feed line. It produces a typical output power level of 1W.

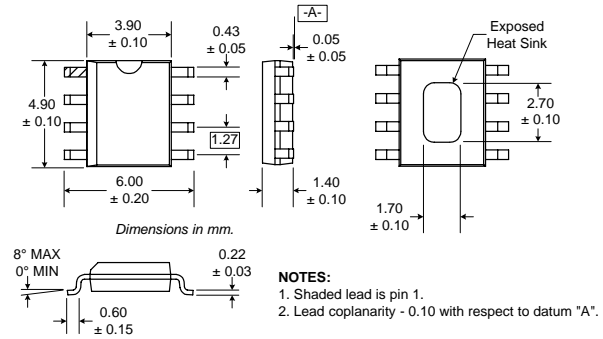

Optimum Technology Matching® Applied

- Si BJT       GaAs HBT       GaAs MESFET  
 Si Bi-CMOS       SiGe HBT       Si CMOS

Package Style: SOIC-8 Slug

- Features
- Single 3V to 6.5V Supply
  - 1.3W Output Power
  - 12dB Gain
  - 45% Efficiency
  - Power Down Mode
  - 1800MHz to 2500MHz Operation

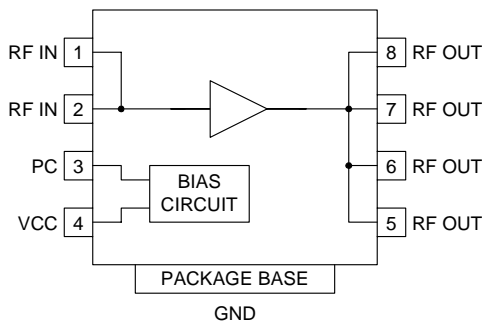

Functional Block Diagram

Ordering Information

RF2126      High Power Linear Amplifier  
 RF2126 PCBA      Fully Assembled Evaluation Board

RF Micro Devices, Inc.      Tel (336) 664 1233  
 7625 Thorndike Road      Fax (336) 664 0454  
 Greensboro, NC 27409, USA      http://www.rfmd.com

# RF2126

## Absolute Maximum Ratings

Parameter	Rating	Unit
Supply Voltage ( $V_{CC}$ )	-0.5 to +7.5	$V_{DC}$
Power Control Voltage ( $V_{PC}$ )	-0.5 to +5V	V
DC Supply Current	450	mA
Input RF Power	+20	dBm
Output Load VSWR	20:1	
Operating Ambient Temperature	-40 to +85	°C
Storage Temperature	-40 to +100	°C

Refer to "Handling of PSOP and PSSOP Products" on page 16-15 for special handling information.



**Caution!** ESD sensitive device.

RF Micro Devices believes the furnished information is correct and accurate at the time of this printing. However, RF Micro Devices reserves the right to make changes to its products without notice. RF Micro Devices does not assume responsibility for the use of the described product(s).

2

POWER AMPLIFIERS

Parameter	Specification			Unit	Condition
	Min.	Typ.	Max.		
<b>Overall</b>					$T=25^{\circ}\text{C}$ , $V_{CC}=6.0\text{V}$ , $V_{PC}=3.0\text{V}$ , $Z_{LOAD}=12\Omega$ , $P_{in} = 0\text{dBm}$ , $\text{Freq}=2450\text{MHz}$ , $\text{Idle current}=180\text{mA}$
Frequency Range	1800		2500	MHz	
Maximum Output Power		+27.0		dBm	$V_{CC}=3.6\text{V}$ , $P_{IN}=+19\text{dBm}$
Maximum Output Power		+29		dBm	$V_{CC}=4.8\text{V}$ , $P_{IN}=+19\text{dBm}$
Maximum Output Power	+30.0	+31.0		dBm	$V_{CC}=6.0\text{V}$ , $P_{IN}=+19\text{dBm}$
Total Power Added Efficiency		45		%	Maximum output, $V_{CC}=3.6\text{V}$
Total Power Added Efficiency		45		%	Maximum output, $V_{CC}=4.8\text{V}$
Total Power Added Efficiency		45		%	Maximum output, $V_{CC}=6.0\text{V}$
Small-signal Gain		12		dB	
Second Harmonic		-55		dBc	See Application Schematic, $P_{IN}=+17\text{dBm}$
Third Harmonic		-60		dBc	
Input VSWR		1.5:1			With external matching network; see application schematic
<b>Two-tone Specification</b>					
Average Two-Tone Power		+27		dBm	PEP-3dB
$IM_3$	-24	-25		dBc	$P_{OUT}=+24\text{dBm}$ for each tone
$IM_5$		-35		dBc	$P_{OUT}=+24\text{dBm}$ for each tone
$IM_7$		-55		dBc	$P_{OUT}=+24\text{dBm}$ for each tone
<b>Power Control</b>					
$V_{PC}$	1.5	3.0	3.5	V	To obtain 180mA idle current
Power Control "OFF"	0.2	0.5		V	Threshold voltage at device input
<b>Power Supply</b>					
Power Supply Voltage	3.0		6.5	V	
Supply Current	270	350	410	mA	$P_{OUT}=+30\text{dBm}$ , $V_{CC}=6.0\text{V}$
Power Down Current		0.5	10	$\mu\text{A}$	$V_{PC}=0.2\text{V}$

Pin	Function	Description	Interface Schematic
1	RF IN	RF input. This input is DC coupled, so an external blocking capacitor is required if this pin is connected to a DC path. An optimum match to $50\Omega$ is obtained by providing an external series capacitor of 1.6pF and then a shunt capacitor of 2.0pF; see the Application Schematic. Those values are typical for 2450MHz; other values may be required for other frequencies.	
2	RF IN	Same as pin 1.	
3	PC	Power control pin. For obtaining maximum performance the voltage on this pin can be used to set correct bias level. In a typical application this is implemented by a feedback loop. The feedback can be based on the actual supply current of the device, i.e. maintaining a fixed current level, or it can be based on the RF output power level to maintain a fixed RF power level (Automatic Level Control loop). A voltage of 0.5V or lower brings the part into power down state.	
4	VCC	Power supply pin for the bias circuits. External low frequency bypass capacitors should be connected if no other low frequency decoupling is nearby.	
5	RF OUT	RF output and bias for the output stage. The power supply for the output transistor needs to be supplied to this pin. This can be done through a quarter-wavelength microstrip line that is RF grounded at the other end, or through an RF inductor that supports the required DC currents. Optimum load impedance is achieved by providing a shunt capacitor of 1.8pF and a series capacitor of 3.3pF; see the Application Schematic. Those values are typical for 2450MHz; other values may be required for other frequencies. Since there are several output pins available, which are internally connected, one pin can be used for connecting the bias, another for connecting a (third) harmonic trap filter, and the other pins for the RF output.	
6	RF OUT	Same as pin 5.	
7	RF OUT	Same as pin 5.	
8	RF OUT	Same as pin 5.	
Pkg Base	GND	Ground connection. The backside of the package should be connected to the ground plane through a short path, i.e., vias under the device may be required.	

## Application Schematic 2450MHz Operation

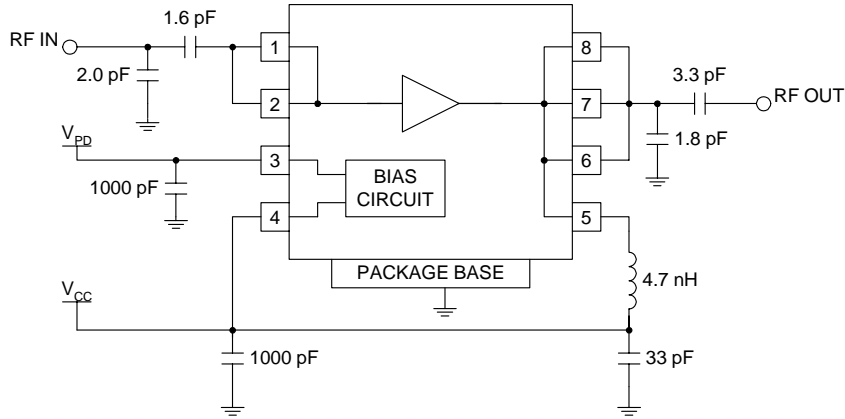

## Evaluation Board Schematic 2450 MHz Operation

(Download [Bill of Materials](http://www.rfmd.com) from [www.rfmd.com](http://www.rfmd.com).)

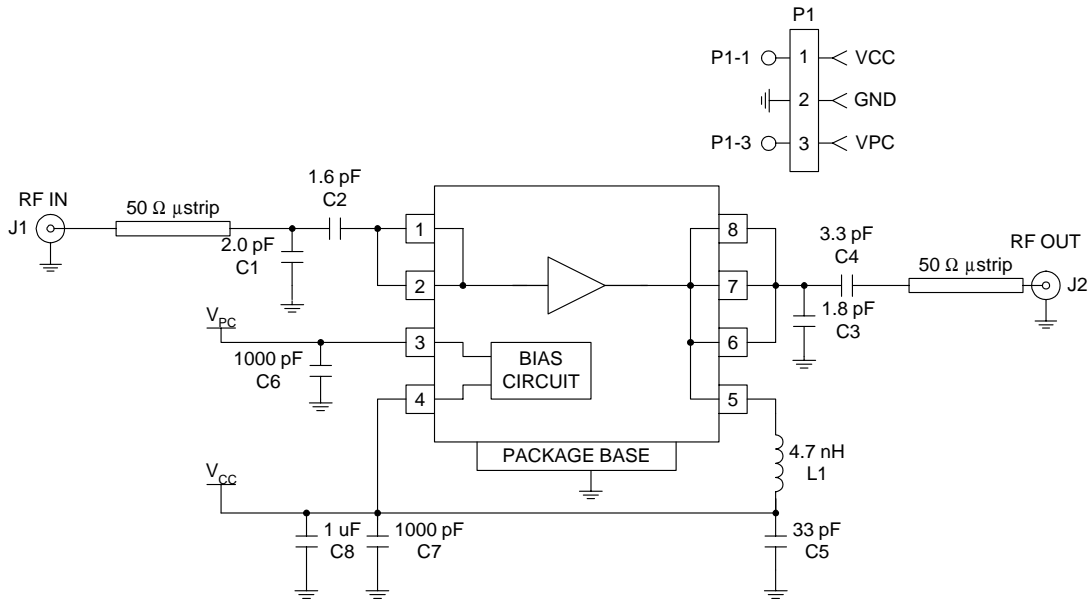

Evaluation Board Layout  
1.5" x 1.0"  
Board Thickness 0.031", Board Material FR-4

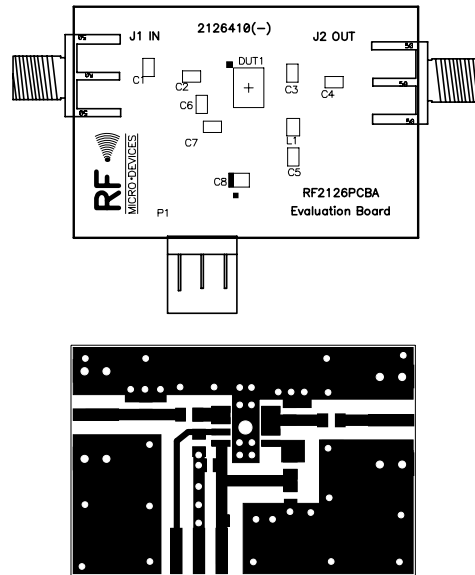

**RF2126**

**2**

**POWER AMPLIFIERS**